

Steam-water mixing valve

Model 253

ENG

In installations with steam, the steam can be mixed with cold water to obtain instant hot water in the most economical way.

Can be used in packaging plants, dairies, detergent plants, slaughterhouses, meat processing plants, hospitals,... etc. For cleaning floors, vehicles, toilets, tanks, filters,... etc. In the manufacture of food, chemical, paper and tannery products,... etc.

Specifications

- Efficient, safe, simple installation and moderate cost.
- Water temperature easily adjusted to suit the needs of the consumer.
- Installation does not require pressure reducing valves.
- In certain applications they make an ideal and economical substitute for heat exchangers.
- Equipped with a safety device which prevents the input of steam until there is water flow through the mixer.
- Design aimed at eliminating noises and vibrations which are characteristics of the mixing of steam with cold water.
- Materials carefully selected for resistance to wear, extreme temperatures and corrosion.
- Simplicity of design, ensuring minimum maintenance requirements.
- Moderate weight and size.
- Easy to connect.
- Three single springs which are easily interchangeable and identified by their colour and number of notches.
- All valves undergo thorough testing.
- Each component is numbered, registered and inspected. If previously requested, the valve will be accompanied by certificates corresponding to materials, batch, tests and performance.

IMPORTANT

Depending on demand:

- Valves made entirely from Stainless steel.
- Valves coated internally and externally with PTFE (Teflon).
- Thermostatic valves.
- Chrome or nickel finish.
- Venturi type doser for mixing detergent with hot water.
- Support for coiling the hose.
- Automatic hose coiler.
- Pistol with lance for spraying hot water.



N°. PIECE	PIECE	MATERIAL
		BRONZE
1	Body	Bronze (EN-CC491K)
2	Cover	Bronze (EN-CC491K)
3	Control	Plastic ABS (1)
4	Piston	Bronze (EN-CC491K)
5	Upper buffer	Bronze (EN-CC491K)
6	Lower buffer	Stainless steel (EN-1.4401)
7	Fixed spring	Stainless steel (EN-1.4310)
8	Axis	Bronze (EN-CC491K-GC)
9	Spring press	Bronze (EN-CC491K)
10/23	Joint	Klingerit cardboard/Fluorelastomer (Vitón)
11	Valve	Brass (EN-CW617N)
12	Lead	Stainless steel (EN-1.4401)
13	Ring	Brass (EN-CW617N)
14	Plate	Stainless steel (EN-1.4401)
15, 25, 27, 36, 41	Screw	Stainless steel (EN-1.4401)
16	Rivets	Stainless steel (EN-1.4401)
17	Seating	PTFE (Teflón)
18, 40	Washer	Copper
19, 49, 52	Washer	Brass (EN-CW617N)
20	Valve	Stainless steel (EN-1.4401)
21	Spring press	Stainless steel (EN-1.4310)
22	Shirt	Bronze (EN-CC491K-GC)
24	Bracket	Polimer + FV (2)
26	Clip	Stainless steel (EN-1.4401)
28, 38	Washer	Stainless steel (EN-1.4401)
29	Adjusting screw	Brass (EN-CW617N)
30	Dowel	Stainless steel (EN-1.4401)
31	Cap	Bronze (EN-CC491K)
32	Gland	Brass (EN-CW617N)
33, 37	Seal	Graphite
34	Cap	Brass (EN-CW617N)
35	Joint	PTFE (Teflón)
39	Gudgeon	Stainless steel (EN-1.4401)
42	Variable spring	Stainless steel (EN-1.4310)
43, 44, 45, 46, 47	Plate	Aluminium
48	Lead	Brass (EN-CW617N)
50	Ball	Stainless steel (EN-1.4401)
51	Nut	Brass (EN-CW617N)
53, 54	Washer	Bronze - Berilium
55	Lower plate	Stainless steel (EN-1.4401)
56	Upper plate	Stainless steel (EN-1.4401)
R		1/2", 3/4", 1" and 1 1/2"(GAS or NPT)
	PN	16
OPERATING CONDITIONS	MAX. STEAM PRESSURE IN bar	10,5
	MIN. STEAM PRESSURE IN bar	0,35
	MAX. TEMPERATURE IN °C	187

(1) The 1 1/2" control is supplied in Aluminium (EN-AC-44200).

(2) R- 1 1/2" is supplied in Bronze (EN-CC491K).

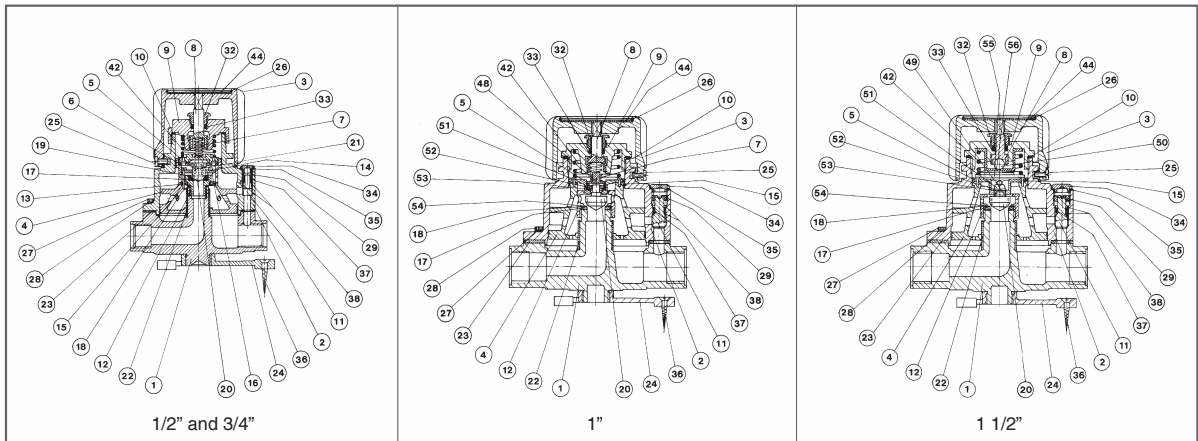

R	VARIABLE SPRING REGULATION RANGE IN bar (STEAM PRESSURE)	IDENTIFICATION COLOUR	N° NOTCHES	MINIMUM HOT WATER FLOW FOR OPEN STEAM VALVE IN l/min.
1/2"	0,35 to 3,50	Black	1	2,30
	3,50 to 7,00	Green	2	2,70
	7,00 to 10,80	Yellow	3	4,50
3/4"	0,35 to 3,50	White	1	7,00
	3,50 to 7,00	Blue	2	7,00
	7,00 to 10,80	Red	3	8,00
1"	0,35 to 3,50	White	1	27,00
	3,50 to 7,00	Blue	2	32,00
	7,00 to 10,80	Red	3	36,00
1 1/2"	0,35 to 3,50	White	1	55,00
	3,50 to 7,00	Blue	2	55,00
	7,00 to 10,80	Red	3	55,00

R	1/2"	3/4"	1"	1 1/2"
CONNECTIONS	Whitworth gas-tight cylindrical female ISO 228/1 (DIN-259) NPT thread ANSI/ASME B1.20.1			
H	197	197	216	286
H1	57	60	70	98
h	32	40	44	60
L	140	151	173	213
F	144	152	201	266
B	108	108	121	143
K	134	159	134	200
DRILLS N°.	3	3	3	3
WEIGHT IN kgs.	6,4	9,4	11,2	26,0
CODE 2106 - 253.	5021	5341	5101	5121

NOTE: The mixing valve is supplied mounted with a variable spring ranging from 3,50 to 7,00 bar and two extra springs are included in case it is required to work at other steam pressures. To change the springs, unscrew the screw (25) remove the control (3) and the spring press (9), and the variable spring (42) will be accessible. To reassemble carry out the reverse sequence.

All valves are supplied with GAS connections and three NPT hoses to choose from.

Flows

Data required to determine the internal diameter of the valve:

- Temperature of consumer hot water:-----
- Flow of consumer hot water:-----
- Pressure available at the cold water input:-----
- Pressure available at the steam input:-----

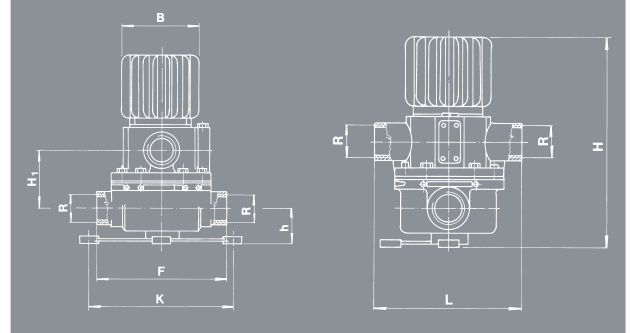

Calculation process

- 1- Start with table for 1/2".
- 2- For the available cold water input pressure, work out the flow of cold water.
- 3- For the available steam input pressure, work out the hot water flow at the consumer temperature.
- 4- From the values obtained in steps 2 and 3 choose the smaller value, and compare if this is sufficient to cover the requirements for consumer hot water. If not repeat the process using the 3/4" table and so on up to the 1 1/2" table.

FLOW R. 1/2"															
COLD WATER			HOT WATER IN l/min.												
PRESSURE IN bar	FLOW IN l/min.		PRESSURE IN bar	SERVICE TEMPERATURE IN °C											
	OPEN VALVE	CLOSED VALVE		38	43	49	54	60	66	71	77	82	88	93	99
0,35	13	7	0,35	13	10	8	7	6	6	5	5	4	4	4	3
0,70	19	9	0,70	21	16	13	11	10	9	8	7	7	6	6	5
1,40	29	11	1,40	32	23	20	17	15	13	12	11	10	9	9	8
2,10	36	13	2,10	38	27	23	20	18	16	14	13	12	11	10	10
2,80	42	14	2,80	49	35	30	26	23	20	19	17	16	15	13	13
3,50	47	15	3,50	62	45	38	33	29	26	24	21	20	18	17	16
4,20	52	16	4,20	67	48	41	35	31	28	26	23	21	20	18	17
4,90	56	17	4,90	72	52	44	38	34	30	27	25	23	21	20	19
5,60	60	18	5,60	77	56	47	41	36	32	29	27	25	23	21	20
6,30	65	19	6,30	82	59	50	43	38	34	31	28	26	24	23	21
7,00	69	19	7,00	87	63	53	46	41	37	33	30	28	26	24	22
7,70	73	19	7,70	91	66	56	49	43	39	35	32	29	27	25	24
8,40	77	20	8,40	97	70	60	52	45	41	37	34	31	29	27	25
9,10	79	20	9,10	102	74	63	54	48	43	39	35	33	30	28	26
9,80	82	21	9,80	107	77	65	57	50	45	41	37	34	32	29	28
10,50	85	21	10,50	112	81	69	60	53	47	43	39	36	33	31	29

FLOW R. 3/4"															
COLD WATER			HOT WATER IN l/min.												
PRESSURE IN bar	FLOW IN l/min.		PRESSURE IN bar	SERVICE TEMPERATURE IN °C											
	OPEN VALVE	CLOSED VALVE		38	43	49	54	60	66	71	77	82	88	93	99
0,35	14	9	0,35	23	19	16	14	12	11	10	9	8	8	7	7
0,70	20	10	0,70	37	28	25	22	19	17	16	14	13	12	11	10
1,40	34	13	1,40	55	45	39	33	30	26	24	22	20	19	17	16
2,10	52	17	2,10	66	54	45	40	35	31	28	26	24	22	20	19
2,80	56	21	2,80	85	72	59	51	45	40	37	34	31	29	27	25
3,50	65	23	3,50	93	89	75	65	57	51	46	42	39	36	34	31
4,20	71	25	4,20	115	95	80	70	61	55	50	45	42	39	36	34
4,90	77	28	4,90	124	101	86	75	66	59	53	49	45	41	38	36
5,60	83	30	5,60	132	108	91	79	70	63	57	52	47	44	41	38
6,30	87	31	6,30	149	122	104	90	79	70	64	58	54	50	46	43
7,00	93	33	7,00	165	136	115	100	88	79	71	65	60	55	51	48
7,70	98	35	7,70	182	149	126	109	97	86	78	71	66	60	57	53
8,40	102	36	8,40	199	163	138	120	105	94	85	78	72	66	62	58
9,10	107	38	9,10	205	168	142	124	109	97	88	80	74	69	64	60
9,80	111	40	9,80	209	171	145	125	111	99	90	81	75	70	65	61
10,50	125	42	10,50	213	174	147	127	112	101	91	83	76	71	66	62

FLOW R.1"																						
COLD WATER PRESSURE IN bar	FLOW IN l/min. ○ OPEN CLOSED VALVE VALVE	STEAM PRESSURE IN bar	HOT WATER IN l/min.																			
			SERVICE TEMPERATURE IN °C																			
			38	43	49	54	60	66	71	77	82	88	93	99								
0,35	55	14	0,35																			
0,70	73	19	0,70	62	45	38	33															
1,40	91	27	1,40	125	91	77	67	59	53	48	44	40	37	34	32							
2,10	105	30	2,10	150	109	92	80	70	63	57	52	48	45	41	39							
2,80	118	32	2,80	170	123	105	90	80	72	65	59	55	50	47	44							
3,50	127	36	3,50	189	138	117	101	89	80	72	66	60	56	52	49							
4,20	141	45	4,20	209	151	129	114	95	85	81	73	67	63	59	55							
4,90	150	45	4,90	227	166	140	122	107	96	87	80	73	68	63	59							
5,60	164	48	5,60	249	182	153	133	107	105	95	86	79	74	69	64							
6,30	168	50	6,30	268	195	165	143	126	113	102	93	86	80	74	69							
7,00	177	52	7,00	288	209	177	154	135	121	110	100	92	85	80	76							
7,70	182	52	7,70	308	223	189	163	145	129	117	107	98	91	85	80							
8,40	191	55	8,40	327	238	201	174	154	137	125	114	105	97	90	85							
9,10	195	57	9,10	348	252	214	185	164	146	132	121	111	103	95	90							
9,80	200	59	9,80	364	266	226	195	173	154	139	127	117	108	101	95							
10,50	200	64	10,50	378	275	233	202	178	159	145	132	121	112	105	97							

FLOW R.1 1/2"																						
COLD WATER PRESSURE IN bar	FLOW IN l/min. ○ OPEN CLOSED VALVE VALVE	STEAM PRESSURE IN bar	HOT WATER IN l/min.																			
			SERVICE TEMPERATURE IN °C																			
			38	43	49	54	60	66	71	77	82	88	93	99								
0,35	70	27	0,35																			
0,70	93	40	0,70	80	58																	
1,40	139	58	1,40	130	95	80	70	61														
2,10	164	69	2,10	170	124	105	91	72	65	59	55											
2,80	192	77	2,80	216	157	133	115	102	91	82	75	69	64	60	56							
3,50	215	85	3,50	258	187	159	137	121	108	98	90	82	76	71	66							
4,20	235	93	4,20	299	218	184	160	141	126	114	104	96	89	83	78							
4,90	235	93	4,90	341	248	210	182	160	144	129	119	109	101	94	88							
5,60	267	106	5,60	380	276	234	202	179	160	145	132	122	113	105	98							
6,30	284	112	6,30	415	302	255	221	195	175	158	144	133	123	115	111							
7,00	300	118	7,00	446	324	275	238	210	188	169	155	143	132	123	115							
7,70	313	124	7,70	474	344	291	253	223	199	180	165	152	140	131	122							
8,40	325	129	8,40	498	362	306	265	234	209	189	173	159	147	139	127							
9,10	340	134	9,10	517	376	318	276	243	218	197	180	165	153	143	134							
9,80	352	139	9,80	533	388	331	284	251	224	202	185	171	158	147	137							
10,50	364	143	10,50	546	397	336	291	257	230	208	190	175	162	150	141							

Operation

For consumer situations the cold water enters the mixer and lifts up the piston, compressing the variable spring. This enables the opening of the steam input valve and the mixing of steam with the cold water to give hot water to the consumer. When there is no consumption, the static water pressure allows the variable spring to close the steam shut off valve to ensure that no steam remains in the mixing chamber in the absence of water.

Installation

- The mixing valve has four connections: Cold water input, steam input, and two hot water outputs. One of the two hot water outputs should be taken out of service by using the corresponding cap and joint. Both outputs can be used simultaneously as long as there is sufficient pressure on the inputs.
- When the mixing valve is used in a closed circuit, it is necessary to generate a pressure loss of 1 bar in order to counterbalance the force of the variable spring to allow the steam to enter the mixing chamber.

Recommended installation example

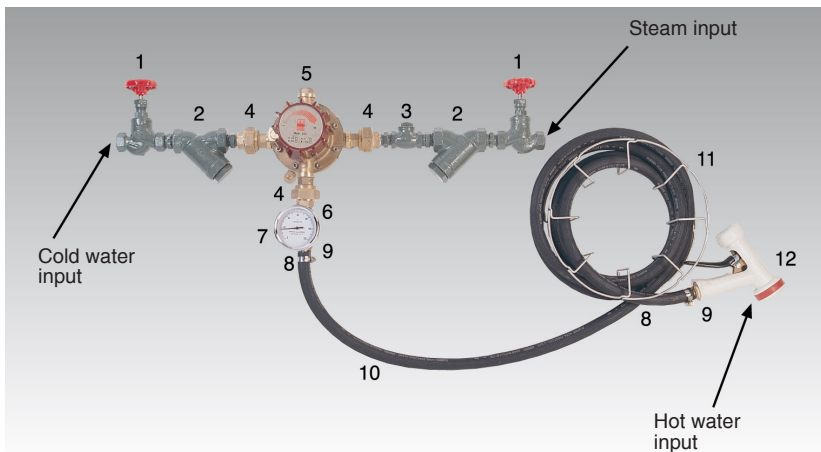

- 1 Interruption valve.
- 2 Filter.
- 3 Check valve.
- 4 Connection.
- 5 Mixing valve.
- 6 Thermometer connection.
- 7 Thermometer.
- 8 Hose connection.
- 9 Clamp.
- 10 Hose.
- 11 Support for coiling the hose or automatic hose coiler.
- 12 Watergun.

IMPORTANT

- We recommend that filters be installed in the cold water and steam inputs in order to protect the internal mechanism of the mixing valve.
- Only use EPDM type P hose, reinforced with internal material.

Start-up and adjustment of the temperature

There are two ways to obtain the required temperature: turning the control (3) on the mixing valve or adjusting the cold water shut off interruption valve (1).

To adjust the valve:

- 1- Remove screw (25) and turn the control (3) from left to right until the end of its travel.
- 2- Remove cap (34).
- 3- Turn valve (1) from left to right and then carry out the reverse process, simultaneously controlling the temperature in the hot water consumption until the required temperature is set.
- 4- Turn the control (3) from right to left to get lower temperatures.
- 5- Insert screw (25), the cap (34) and tighten them up.

Maintenance

We recommend cleaning the inside of the valve only if the water is specially hard, using a descaling product or a light solution of 7 parts water to one part hydrochloric acid.

Watergun

PI-1

Specifications

- Body of bronze covered with black synthetic rubber.
- Operated using rear-mounted trigger, more manageable, safe and less tiring.
- Instant, automatic and water-proof closure.
- Ring on one end of the pistol for hanging after use or for insertion in the trigger for a fixed setting in order to obtain an effortless, continuous flow.

Spray adjustment

- 1- Fine spray: Press lightly on the trigger.
 Adjustable using the adjustment screw located at the other end from the water output.
- 2- Constant spray: Press the trigger fully on.

R	1/2"
CONNECTIONS	NPT ANSI-B2.1 for connection M-NPT or M-GAS Whitworth conical ISO 7-1 (EN 10226) (DIN-259)
HOLE Ø	11
WEIGHT IN kgs.	1,20
CODE	2106-253.0000

HOT WATER FLOW		
R	1/2"	
PRESSURE IN bar	FLOW IN l/min.	
0,35	13,50	
0,70	19,30	
3,40	37,80	
7,00	45,00	
17,50	54,00	
24,50	85,50	
28,00	90,00	
OPERATING CONDITIONS	MAX. PRESSURE IN bar	28
	MAX. HOT WATER TEMP. IN °C	82