

**PRESSURE REDUCING VALVE
DIRECT ACTING
PRV20**

MAIN FEATURES

Self-actuating pressure reducing valve balancing by piston used to provide a constant downstream with oscillations in inlet pressure.

Valve closes when outlet pressure increases.

Easy to adjust and doesn't need any maintenance. It's possible to install the valve in any position.

Pressure ranges:

- 0,2 to 2 barg
- 1 to 8 barg
- 5 to 20 barg

The pressure reducing valve is not a safety valve, and then if necessary, an overpressure protection must be installed.

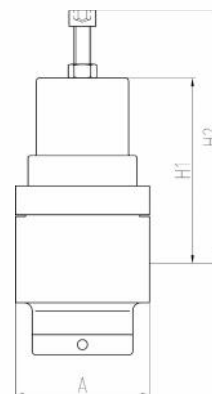

Max. permissible upstream pressure	40 barg
Max. permissible temperature	-20 to 80°C (Other on request)
Sizes	1/4" - 3/8" - 1/2" - 3/4"
Connections	Threaded BSP or NPT (other, on request)
Body material	Stainless steel AISI 316L (1.4404) (Bronze, on request)
Trim material	Stainless steel AISI 316L (1.4404)
Gasket material	NBR, FKM, EPDM (Specially gaskets material on request)
Characteristics	It does not need any maintenance. Special Kv available under request
More common applications	Chemical laboratory installations, sanitary plants, compressed air, sprinkler systems, ...

DN	1/4"	3/8"	1/2"	3/4"
Kv value	1,2	1,8	2,1	2,4
A	80			
H1	110			
H2	150 - 180			
Weight (Kg)	3.5			

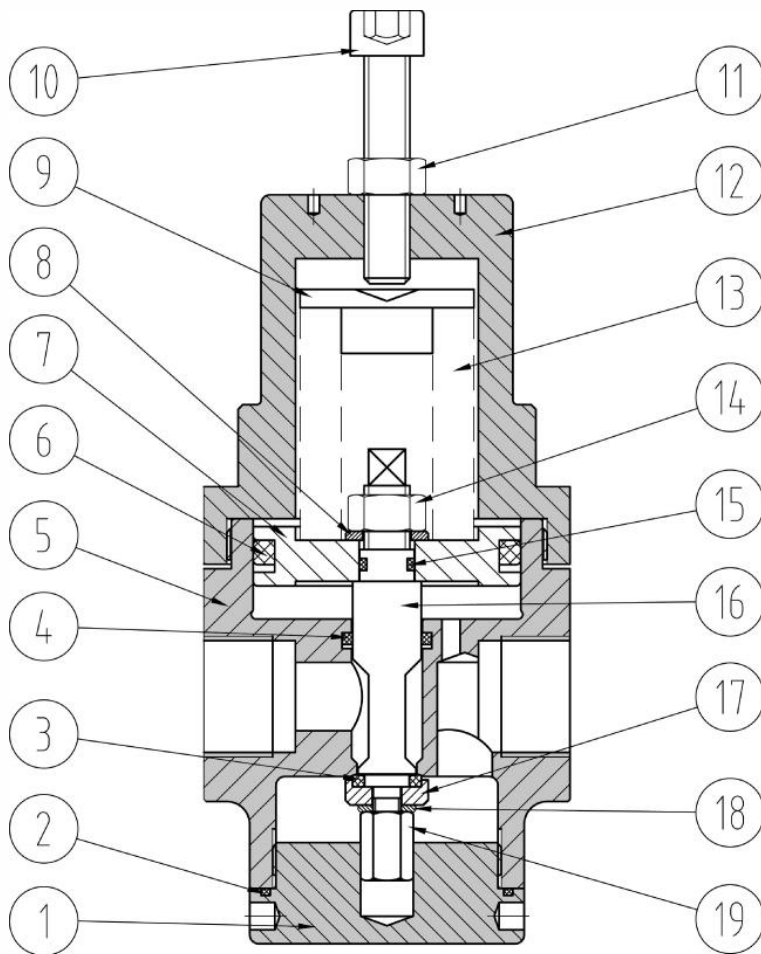

	DESCRIPTION	MATERIAL
1	Lower Cover	1.4404 - SS 316L
2	O-ring	NBR
3	Seal	NBR
4	O-ring	NBR
5	Body	1.4404 - SS 316L
6	Quadring O-ring	NBR
7	Piston	1.4404 - SS 316L
8	Washer	A2-70
9	Washer spring	1.4404 - SS 316L
10	Regulation screw	Stainless steel A2-70
11	Nut	A2-70
12	Spring cover	1.4404 - SS 316L
13	Regulation spring	Spring steel 52SiCrNi5
14	Nut	A2-70
15	O-ring	NBR
16	Stem	1.4404 - SS 316L
17	Guide seal	1.4404 - SS 316L
18	Washer	A2-70
19	Nut	1.4404 - SS 316L
		Special gaskets for special fluid on demand

OPERATION

PRV concept is direct action. Inlet pressure comes into the valve and closes it because of the sections difference. When we compress the spring (13) through the regulating screw (10), the stem-seal (16, 3, 17) opens the valve and allows the regulation.

When any downstream valve is closed and flow=0, PRV will absorb the oscillations and keep the outlet pressure according to the regulation.

The valve closes when the downstream pressure exceeds the regulating set pressure.

It is recommended to leave a distance (between 0,5 and 1 meter) until the check valve, for a better compensation.

To increase outlet pressure, the regulating screw should be turned clockwise.

Classification according pressure equipment Directive, PED 2014/68/UE					
Fluid	PN	Size	Category	CE marked	Chart
Gases and liquids of group 2	PN40	DN8 – DN20	Apar 3-art 3	No requerido / Not required	7

