

**Full lift safety valve with spring loading.(AIT)
 Model 496**

ENG

DESCRIPTION

Specifications

- 90° angular flow.
- Activated by direct action helicoid spring.
- Simplicity of construction ensuring minimum maintenance.
- Materials carefully selected for their resistance to corrosion. With the exception of washers and couplings, the valves are free of non-ferric materials.
- Internal body designed to offer favourable flow profile.
- Sealing surfaces treated and balanced, making them extremely tightness, even exceeding EN 12266-1 requirements.— Great discharge capacity. For liquids typically used with openings similar to proportional safety valves.
- Equipped with draining screws for removing condensation.
- Auto-centering plug.
- Threaded shaft with lever positioner facilitating immediate manual action.
- Elevator, independent of the seal, designed facilitate sudden opening when the steam expands and, with any fluid, guarantees absolute opening and closing precision.
- All the valves are supplied sealed at the set pressure requested, simulating operational conditions, and are vigorously tested.
- All components are numbered, registered and checked. If requested in advance, material, casting, test and efficiency



IMPORTANT

Depending on demand:

- 1.- Blocking screw which facilitates hydrostatic testing of the container which to be protected.
- 2.- Rapid limiter to reduce the coefficient of discharge.
- 3.- Fluorelastomer (Vitón) seals, Silicone's rubber, PTFE (Teflón)... etc., achieving leakage levels less than $0,3 \times 10^{-3} \frac{\text{Pa cm}^3}{\text{seg.}}$

The ranges of application allow certain flexibility although we recommend limiting them to:

RANGE OF APPLICATION FOR THE SEALS					
FLUID	SET PRESSURE IN bar				
	0,2	1,8	4,0	4,8	7,0
Saturated steam	S	V	T		
Liquids and gases	S		V		T
SEALS	TEMPERATURE IN °C				
		ACCORDING TO MANUFACTURERS		RECOMMENDED BY VYC	
		MINIMUM	MAXIMUM	MINIMUM	MAXIMUM
Silicone's rubber	S	-60	+200	-50	+115
Fluorelastomer (Vitón)	V	-40	+250	-30	+150
PTFE (Teflón)	T	-265	+260	-80	+230 (1)

(1) For temperatures exceeding 230°C apply metallic seal only.

- 4.- Fluorelastomer (Vitón) membrane and O-ring isolating the rotating or sliding parts from the working fluid.
- 5.- Electrical contact indicating open/closed.
- 6.- Balance bellows to:
 - Protect the spring from atmospheric influences.
 - Ensure outside of valve body is totally tightness.
 - Level out external or self-generated back pressure.
- 7.- Possibility of manufacture in other types of material, for special operating conditions (high temperatures, fluids, etc.).
- 8.- Totally free of oil and grease, to work with oxygen, avoiding possible fire risks (UV-Oxygen-VBG 62).
- 9.- Special springs for critical temperatures.

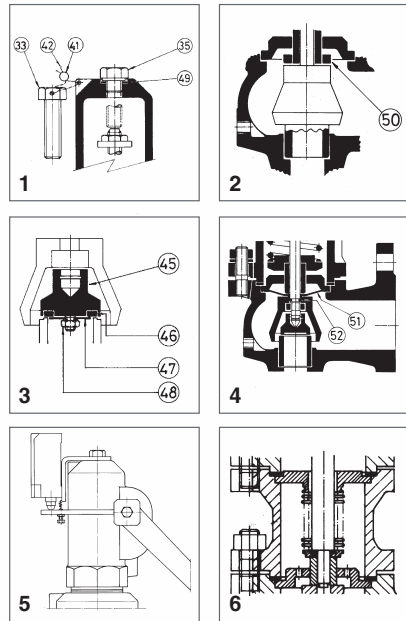

N°. PIECE	PIECE	MATERIAL																			
		CAST IRON				NODULAR IRON					CAST STEEL				STAINLESS STEEL						
1	Body	Cast iron (EN-5.1301)				Nodular iron (EN-5.3106)					Cast steel (EN-1.0619+N)				Stainless steel (EN-1.4408)						
2	Closed bell	Cast iron (EN-5.1301)				Nodular iron (EN-5.3106)					Nodular iron (EN-5.3106)				Stainless steel (EN-1.4408)						
3	Open bell	Cast iron (EN-5.1301)				Nodular iron (EN-5.3106)					Cast steel (EN-1.0619+N)				Stainless steel (EN-1.4408)						
4, 5, 6	Hood	Nodular iron (EN-5.3106)				Nodular iron (EN-5.3106)					Nodular iron (EN-5.3106)				Stainless steel (EN-1.4408)						
7	Elevator	Nodular iron (EN-5.3106) (1)				Nodular iron (EN-5.3106) (1)					Nodular iron (EN-5.3106) (1)				Stainless steel (EN-1.4408)(7)						
8	Cam	Carbon steel (EN-1.0037 St-37.2) (6)				Carbon steel (EN-1.0037 St-37.2) (6)					Carbon steel (EN-1.0037 St-37.2) (6)				Stainless steel (EN-1.4301)						
9, 10	Lever	Carbon steel (EN-1.0037 St-37.2)				Carbon steel (EN-1.0037 St-37.2)					Carbon steel (EN-1.0037 St-37.2)				Carbon steel (EN-1.0037 St-37.2)						
11	Seating	Stainless steel (EN-1.4028)				Stainless steel (EN-1.4028)					Stainless steel (EN-1.4028)				Stainless steel (EN-1.4542)						
12	Plug	Stainless steel (EN-1.4028)				Stainless steel (EN-1.4028)					Stainless steel (EN-1.4028)				Stainless steel (EN-1.4542)						
13	Lead	Stainless steel (EN-1.4028) (4)				Stainless steel (EN-1.4028) (4)					Stainless steel (EN-1.4028) (4)				Stainless steel (EN-1.4401) (5)						
14	Spring press	Carbon steel (EN-1.1191)				Carbon steel (EN-1.1191)					Carbon steel (EN-1.1191)				Stainless steel (EN-1.4305)						
15	Separator	Stainless steel (EN-1.4028)				Stainless steel (EN-1.4028)					Stainless steel (EN-1.4028)				Stainless steel (EN-1.4401)						
16	Rod	Stainless steel (EN-1.4028)				Stainless steel (EN-1.4028)					Stainless steel (EN-1.4028)				Stainless steel (EN-1.4401)						
17	Lever shaft	Carbon steel (EN-1.1191)				Carbon steel (EN-1.1191)					Carbon steel (EN-1.1191)				Stainless steel (EN-1.4305)						
18	Gudgeon	Carbon steel (EN-1.1231)				Carbon steel (EN-1.1231)					Carbon steel (EN-1.1231)				Stainless steel (EN-1.4310)						
19	Ring	Stainless steel (EN-1.4028)				Stainless steel (EN-1.4028)					Stainless steel (EN-1.4028)				Stainless steel (EN-1.4401)						
20, 21	Safety ring	Stainless steel (EN-1.4310)				Stainless steel (EN-1.4310)					Stainless steel (EN-1.4310)				Stainless steel (EN-1.4310)						
22	Spring	Vanadium-chrome steel (EN-1.8159) (2)				Vanadium chrome steel (EN-1.8159) (2)					Vanadium chrome steel (EN-1.8159) (2)				Stainless steel (EN-1.4310) (3)						
23	Gland	Carbon steel (EN-1.1191)				Carbon steel (EN-1.1191)					Carbon steel (EN-1.1191)				Stainless steel (EN-1.4305)						
24	Hollow screw	Stainless steel (EN-1.4305)				Stainless steel (EN-1.4305)					Stainless steel (EN-1.4305)				Stainless steel (EN-1.4305)						
25	Hollow screw nut	Stainless steel (EN-1.4305)				Stainless steel (EN-1.4305)					Stainless steel (EN-1.4305)				Stainless steel (EN-1.4305)						
26	Buffer nut	Stainless steel (EN-1.4305)				Stainless steel (EN-1.4305)					Stainless steel (EN-1.4305)				Stainless steel (EN-1.4305)						
27	Rod check nut	Carbon steel (EN-1.1141)				Carbon steel (EN-1.1141)					Carbon steel (EN-1.1141)				Stainless steel (EN-1.4401)						
28, 29, 48	Nut	Carbon steel (EN-1.1141)				Carbon steel (EN-1.1141)					Carbon steel (EN-1.1141)				Stainless steel (EN-1.4401)						
30, 31	Washer	Carbon steel (EN-1.1141)				Carbon steel (EN-1.1141)					Carbon steel (EN-1.1141)				Stainless steel (EN-1.4401)						
32	Stud	Carbon steel (EN-1.1181)				Carbon steel (EN-1.1181)					Carbon steel (EN-1.1181)				Stainless steel (EN-1.4401)						
33, 34, 35	Screw	Carbon steel (EN-1.1191)				Carbon steel (EN-1.1191)					Carbon steel (EN-1.1191)				Stainless steel (EN-1.4401)						
36	Cap	Carbon steel (EN-1.1181)				Carbon steel (EN-1.1181)					Carbon steel (EN-1.1181)				Stainless steel (EN-1.4401)						
38	Coupling	Graphite				Graphite					Graphite				PTFE (Teflón)						
39	Coupling	PTFE (Teflón)				PTFE (Teflón)					PTFE (Teflón)				PTFE (Teflón)						
40	Seal	Graphite				Graphite					Graphite				PTFE (Teflón)						
41	Seal	Plastic				Plastic					Plastic				Plastic						
42	Sealing wire	Sealing wire				Sealing wire					Sealing wire				Sealing wire						
43	Characteristic plate	Stainless steel (EN-1.4301)				Stainless steel (EN-1.4301)					Stainless steel (EN-1.4301)				Stainless steel (EN-1.4301)						
45	Plug	Stainless steel (EN-1.4401)				Stainless steel (EN-1.4401)					Stainless steel (EN-1.4401)				Stainless steel (EN-1.4401)						
46	Sealing disk	PTFE (Teflón)				PTFE (Teflón)					PTFE (Teflón)				PTFE (Teflón)						
		Silicone's rubber				Silicone's rubber					Silicone's rubber				Silicone's rubber						
		Fluorelastomer (Vitón)				Fluorelastomer (Vitón)					Fluorelastomer (Vitón)				Fluorelastomer (Vitón)						
47	Washer	Stainless steel (EN-1.4401)				Stainless steel (EN-1.4401)					Stainless steel (EN-1.4401)				Stainless steel (EN-1.4401)						
49	Coupling	Copper				Copper					Copper				PTFE (Teflón)						
50	Limiter	Stainless steel (EN-1.4028)				Stainless steel (EN-1.4028)					Stainless steel (EN-1.4028)				Stainless steel (EN-1.4401)						
51	Membrane	Fluorelastomer (Vitón)				Fluorelastomer (Vitón)					Fluorelastomer (Vitón)				Fluorelastomer (Vitón)						
52	O-ring	Fluorelastomer (Vitón)				Fluorelastomer (Vitón)					Fluorelastomer (Vitón)				Fluorelastomer (Vitón)						
DN ₁ x DN ₂		20 x 32 to 200 x 300																			
PN		16				40					40				40						
OPERATING CONDITIONS	PRESSURE IN bar	16	13	13	13	40	35	32	28	24	40	35	32	28	24	21	20	40	34	32	29
	MAX. TEMP. IN °C	120	200	250	300	120	200	250	300	350	120	200	250	300	350	400	450	120	200	250	300
	MIN. TEMP. IN °C	-10				-10					-10				-60						

(1) DN-20 x 32 in stainless steel (EN-1.4408).

(2) Spring steel (EN-10270-1-SH) for wire spring $\phi < 10$ mm. Maximum temperature EP, ES and CP 250°C / AP 400°C.

(3) Vanadium chrome steel (EN-1.8159) for wire spring $\phi > 10$ mm.

(4) DN-200x300 in Stainless steel (DIN-1.4027).

(5) DN-200x300 in Stainless steel (EN-1.4408).

(6) DN-20x32 in Stainless steel (DIN-1.4301).

(7) DN-32x50 to DN-65x100 in Stainless steel (DIN-1.4401).



CASPANI NUOVE TECNOLOGIE

Montano Lucino CO - Via dell'industria 3a

Tel 031/471714 Fax 031/470351

www.cntcaspani.com

Full lift safety valve with spring loading (AIT) model 496 - AP and CP.

1. Disassembly and assembly.

1.1 Disassembly.

To replace the spring (22) or clean any of the internal components of the valve, proceed in the following manner:

A - Withdraw the clip (18), using a punching tool, until the lever (10) comes free.

B - Loosen the screws (34) and take the cap (6) off.

C - Holding the spindle (16) steady, loosen the hollow screw nut (25) and the hollow screw (24) until you note a releasing of the spring (22).

D - Mark on the spindle (16) the position of the spindle lock-nut (27) and the adjusting nut (26). Loosen them and remove them.

E - Unscrew the nuts (29) and remove them, together with the studs (32) and their washers (30).

F - Lift the cover (3) or (2) and you will have access to all of the components.

1.2 Assembly.

A - Place the safety-ring (20) on the spindle (16) and press it against the gasket (12).

B - In the spindle channel (16) connect the ring (19) and fix it to the security-ring (21). Introduce the elevator (7) into the upper part of the spindle (16) and press this against the previously described pieces.

C - Enter the guide (13), the separator (15), the spring-press (14), the spring (22), the spring-press (14) through the upper part of the spindle (16) and press this against the previously described pieces.

D - Replace the assembly (38) and the cover (3) or (2).

E - Place the washers (30) on the studs (32) and make up the nuts (29) diagonally, checking the correct alignment of the cover (3) or (2).

F - Adjust the firing pressure with the hollow screw (24) and fix the adjustment position with the hollow screw nut (25).

G - Turn the spindle lock-nut (27) and the adjusting nut (26) to the position marked (see 1.1.D) and make up against each other.

H - Introduce the cap (6) and tighten the screws (34).

I - Place the lever (10) and fix it with the fastener (18).

2. Adjusting the firing pressure.

A - Proceed according to points 1.1.A, 1.1.B, 1.1.C.

B - Proceed according to points 1.2.F, 1.2.H, 1.2.I.

Full lift safety valve with spring loading (AIT) model 496 - EP.

1. Disassembly and assembly.

1.1 Disassembly.

To replace the spring (22), or clean any of the internal components of the valve, proceed in the following manner:

A - Move the lever (9) in direction C as far as the constructive catcher.

B - Unscrew the cap (4) and remove.

C - Holding the spindle (16) steady, loosen the hollow screw nut (25) and the hollow screw (24) until you note a releasing of the spring (22).

D - Mark on the spindle (16) the position of the spindle lock-nut (27) and the adjusting nut (26). Loosen them and remove them.

E - Unscrew the nuts (29) and remove them, together with the studs (32) and their washers (30).

F - Lift the cover (2) and you will have access to all of the components.

1.2 Assembly.

A - Place the safety-ring (20) on the spindle (16) and press it against the gasket (12).

B - In the spindle channel (16) connect the ring (19) and fix it to the security-ring (21). Introduce the elevator (7) into the upper part of the spindle (16) and press this against the previously described pieces.

C - Enter the guide (13), the separator (15), the spring-press (14), the spring (22), the spring-press (14) through the upper part of the spindle (16) in a correlative manner.

D - Replace the assembly (38) and the cover (2).

E - Place the washers (30) on the studs (32) and make up the nuts (29) diagonally, checking the correct alignment of the cover (2).

F - Adjust the firing pressure with the hollow screw (24) and fix the adjustment position with the hollow screw nut (25).

G - Turn the spindle lock-nut (27) and the adjusting nut (26) to the position marked (see 1.1.D) and make up against each other.

H - Change the coupling (39) and lightly tighten the cap (4). Move the lever (9) towards position A as far as the constructive catcher. Definitively tighten the cap (4).

2. Adjusting the firing pressure.

A - Proceed according to points 1.1.A, 1.1.B, 1.1.C.

B - Proceed according to points 1.2.F, 1.2.H.

Full lift safety valve with spring loading (AIT) model 496 - ES.

1. Disassembly and assembly.

1.1 Disassembly.

To replace the spring (22), or clean any of the internal components of the valve, proceed in the following manner:

A - Unscrew the cap (5) and remove.

B - Holding the spindle (16) steady, loosen the hollow screw nut (25) and the hollow screw (24) until you note a releasing of the spring (22).

C - Unscrew the nuts (29) and remove them, together with the studs (32) and their washers (30).

F - Lift the cover (2) and you will have access to all of the components.

1.2 Assembly.

A - Place the safety-ring (20) on the spindle (16) and press it against the gasket (12).

B - In the spindle channel (16) connect the ring (19) and fix it to the security-ring (21).

Introduce the elevator (7) into the upper part of the spindle (16) and press this against the previously described pieces.

C - Enter the guide (13), the separator (15), the spring-press (14), the spring (22), the spring-press (14) through the upper part of the spindle (16) in a correlative manner.

D - Replace the washers (38) and the cover (2).

E - Place the washers (30) on the studs (32) and make up the nuts (29) diagonally, checking the correct alignment of the cover (2).

F - Adjust the firing pressure with the hollow screw (24) and fix the adjustment position with the hollow screw nut (25).

G - Change the coupling (39) and tighten the cap (5).

2. Adjusting the firing pressure.

A - Proceed according to points 1.1.A, 1.1.B.

B - Proceed according to points 1.2.F, 1.2.G.

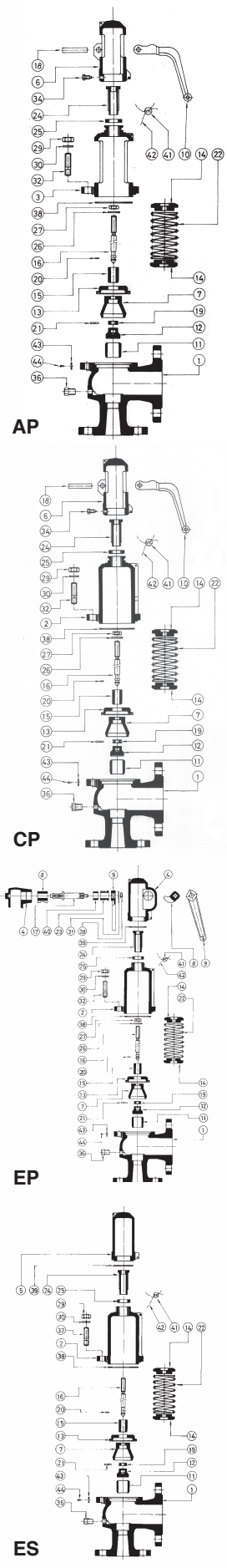

SET PRESSURES AND REGULATING RANGES

DN ₁ x DN ₂		20 x 32	25 x 40	32 x 50	40 x 65	50 x 80	65 x 100	80 x 125	100 x 150	125 x 200	150x250	200x300	
SET PRESSURES IN bar	MAXIMUM (LIQUIDS AND GASES)	PN-16	16	16	16	16	16	16	16	16	12,5	10	8
		PN-40	40	40	40	32	32	32	25	20	12,5	10	8
	MAXIMUM (SATURATED STEAM)	PN-16	13	13	13	13	13	13	13	13	12,5	10	8
		PN-40	32	32	30	24	22	24	20	18	12,5	10	8
	MINIMUM	STEAM AND GASES	0,5	0,5	0,5	0,5	0,5	0,5	0,5	0,5	0,5	0,5	0,5
		LIQUIDS	0,2	0,2	0,2	0,2	0,2	0,2	0,2	0,2	0,2	0,2	0,2
SPRING REGULATING RANGE IN bar	0,20 to 0,68	CODE	56210 56390	56226 56406	56242 56422	56258 56438	56453 56453	56288 56468	56303 56483	56317 56497	56500	56511	56521
	0,66 to 1,00	CODE	56211 56391	56227 56407	56243 56423	56259 56439	56454 56454	56289 56469	56304 56484	56318	56501	56512	56522
	0,95 to 1,40	CODE	56212 56392	56228 56408	56244 56424	56260 56440	56455 56455	56290 56470	56305 56485	56319	56502	56513	56523
	1,30 to 1,90	CODE	56213 56393	56229 56409	56245 56425	56261 56441	56456 56456	56291 56471	56306 56486	56320	56503	56514	56524
	1,80 to 2,60	CODE	56214 56394	56230 56410	56246 56426	56262 56442	56457 56457	56292 56472	56307	56321	56504	56515	56525
	2,50 to 3,60	CODE	56215 56395	56231 56411	56247 56427	56263 56443	56458 56458	56293 56473	56308	56322	56505	56516	56526
	3,50 to 5,00	CODE	56216 56396	56232 56412	56248 56428	56264 56444	56459 56459	56294	56309	56323	56506	56517	56527
	4,80 to 6,30	CODE	56217 56397	56233 56413	56249 56429	56265 56445	56460 56460	56295	56310	56324	56507	56518	56528
	6,00 to 8,00	CODE	56218 56398	56234 56414	56250 56430	56266 56446	56461 56461	56296	56311	56325	56508	56519	56529
	7,50 to 10,00	CODE	56219 56399	56235 56415	56251 56431	56267 56447	56462 56462	56297	56312	56326	56509	56520	
	9,50 to 12,50	CODE	56220 56400	56236 56416	56252 56432	56268 56448	56283	56298	56313	56327	56510		
	12,00 to 16,00	CODE	56221 56401	56237 56417	56253 56433	56269 56449	56284	56299	56314	56328			
	15,00 to 20,00	CODE	56222 56402	56238 56418	56254 56434	56270	56285	56300	56315	56329			
	18,00 to 25,00	CODE	56223 56403	56239 56419	56255 56435	56271	56286	56301	56316				
	23,00 to 32,00	CODE	56224 56404	56240 56420	56256 56436	56272	56287	56302					
	30,00 to 40,00	CODE	56225 56405	56241 56421	56257 56437								

Spring steel (EN-10270-1-SH). Maximum temperature for EP, ES and CP models 250°C / AP 400°C.

Vanadium-chrome steel (EN-1.8159).

Stainless steel (EN-1.4310).

COEFFICIENT OF DISCHARGE											
DN1 x DN2	20 x 32	25 x 40	32 x 50	40 x 65	50 x 80	65 x 100	80 x 125	100 x 150	125x200	150x250	200x300
do	16	20	25	32	40	50	63	77	93	110	155
h	7,00	9,00	12,00	12,00	18,00	18,00	20,00	29,00	34,40	36,80	56,15
h1	2,60	3,20	4,00	5,20	6,50	8,00	10,00	12,50	16,74	19,80	27,90
h/do	0,44	0,45	0,48	0,38	0,45	0,36	0,32	0,38	0,37	0,33	0,36
h1/do (1)	0,16	0,16	0,16	0,16	0,16	0,16	0,16	0,16	0,18	0,18	0,18
COEFFICIENT OF DISCHARGE kd	SATURATED STEAM GASES	0,78						0,78		0,78	0,74
	LIQUIDES	0,60								0,52	
	LIQUIDS WITH RAPID LIMITER (1)	0,36									

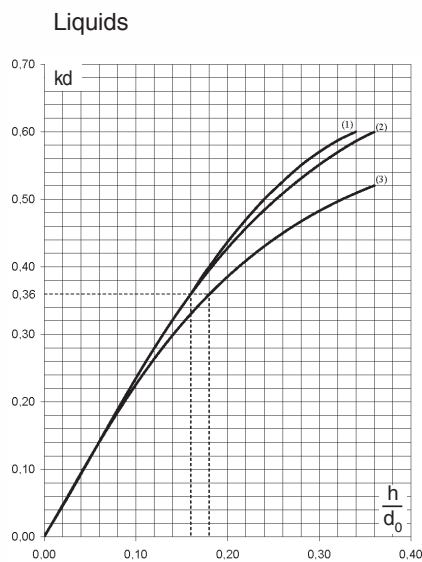
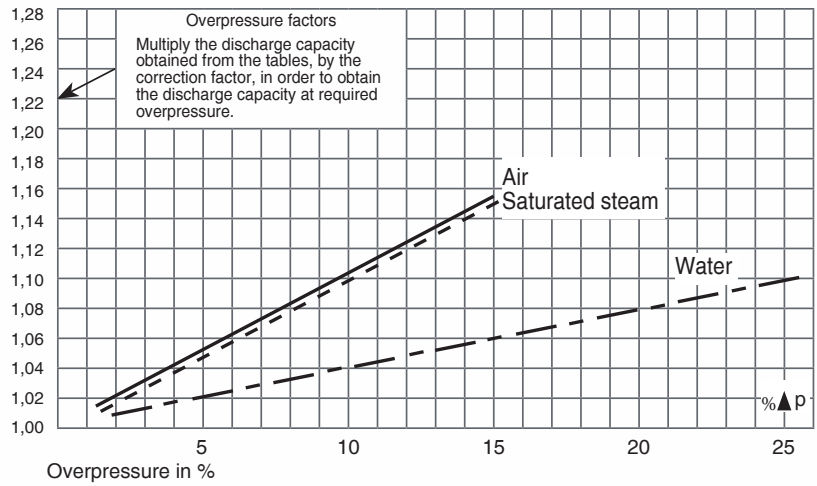
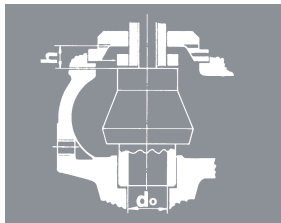

- (1) d_0 16-63
- (2) d_0 77
- (3) d_0 93-155

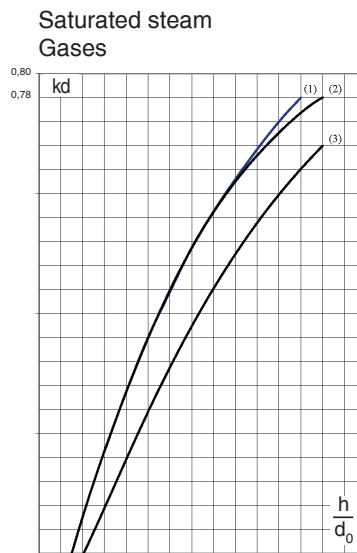

- (1) d_0 16-77
- (2) d_0 93-110
- (3) d_0 155

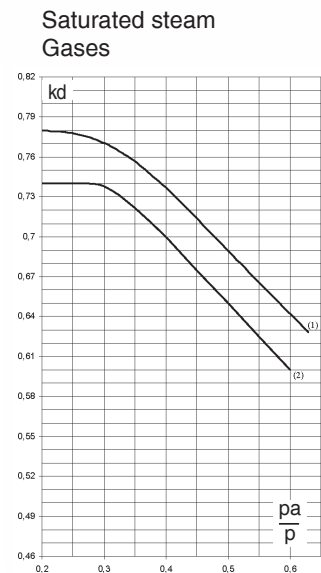

- (1) d_0 16-110
- (2) d_0 155

DN1 x DN2	20 x 32	25 x 40
do	16	20
Ao= $\frac{\pi \cdot do^2}{4}$	201	314

DISCHARGE CAPACITY

32 x 50	40 x 65	50 x 80	65 x 100	80 x 125	100 x 150	125 x 200	150 x 250	200 x 300
25	32	40	50	63	77	93	110	155
491	804	1257	1964	3117	4657	6793	9503	18870

For other, not so dense liquids, other than water at 20°C apply:

I - Saturated steam in kg/h.

II - Air at 0°C and 1,013 bar in [Nm³/h].

III - Water at 20°C in l/h.

$$\sqrt{\frac{Q_A}{Q_L}} \cdot V_A \cdot \dot{O} \quad V_A = V_L \cdot \sqrt{\frac{Q_L}{Q_A}}$$

V_A = Water flow according to table.
V_L = Liquid flow.
Q_A = Water density at a 20°C.
(Q_A = 998 kg/m³)
Q_L = Liquid density

p [bar]	SET PRESSURE IN bar					
	I	II	III	I	II	III
0,5	101	121	4310	157	200	6734
1,0	151	182	6096	236	285	9523
1,5	200	244	7466	312	380	11664
2,0	246	300	8621	385	469	13468
2,5	290	356	9639	453	569	15058
3,0	334	414	10559	522	648	16495
3,5	375	466	11405	585	730	17817
4,0	415	518	12192	648	811	19047
4,5	455	570	12932	711	892	20202
5,0	496	622	13632	774	973	21295
6,0	576	725	14933	899	1135	23328
7,0	656	829	16129	1024	1298	25197
8,0	736	933	17243	1149	1460	26936
9,0	815	1036	18288	1273	1622	28570
10,0	894	1140	19278	1397	1784	30116
12,0	1053	1347	21118	1645	2109	32990
14,0	1211	1555	22810	1891	2433	35634
16,0	1369	1762	24385	2139	2758	38094
18,0	1526	1969	25864	2384	3082	40405
20,0	1684	2177	27263	2631	3407	42590
22,0	1841	2384	28594	2876	3731	44669
24,0	2000	2592	29865	3124	4056	46656
26,0	2157	2799	31085	3370	4380	48561
28,0	2316	3006	32258	3618	4705	50394
30,0	2472	3214	33390	3861	5029	52163
32,0	2630	3421	34486	4109	5353	53873
34,0		3628	35547		5678	55531
36,0		3836	36578		6002	57141
38,0		4043	37580		6327	58707
40,0		4250	38556		6651	60232

I	II	III	I	II	III	I	II	III	I	II	III	I	II	III	I	II	III	I	II	III	I	II	III			
246	294	10530	402	482	17243	629	738	26958	982	1168	42120	1559	1845	66848	2330	2773	99876	4488	6470	126790	6278	9051	178083	11827	17051	333617
369	435	14892	604	724	24385	945	1134	38125	1476	1771	59568	2343	2811	94538	3500	4200	141246	5877	9018	179308	8222	12615	251847	15490	23766	500090
488	590	18239	799	960	29866	1249	1498	46693	1952	2342	72955	3097	3716	115785	4628	5431	172990	7262	11272	219606	10159	15769	308449	19139	29707	612483
602	728	21060	986	1191	34486	1541	1863	53916	2408	2913	84241	3821	4622	133697	5709	6907	199752	8644	13527	253580	12092	18923	356166	22779	35649	707235
708	857	23546	1160	1415	38556	1813	2194	60280	2833	3429	94185	4496	5444	149478	6717	8134	223329	10013	15781	283511	14008	22077	398206	26389	41590	790712
817	1017	25793	1337	1664	42236	2090	2605	66034	3266	4070	103174	5184	6376	163746	7745	9526	244645	11382	18036	310570	15923	25231	436212	29997	47531	866182
916	1145	27860	1499	1872	45620	2343	2931	71325	3661	4579	111441	5811	7260	176665	8682	10820	264247	12744	20290	335454	17828	28385	471163	33585	53473	935583
1014	1272	29784	1660	2080	48770	2596	3256	76249	4056	5088	119136	6437	8066	189077	9617	12023	282492	14099	22545	358616	19724	31539	503695	37158	53414	1000181
1112	1399	31590	1821	2288	51729	2847	3582	80874	4449	5596	126362	7060	8873	200547	10548	13225	299628	15460	24799	380369	21628	34692	534249	40743	65356	1060882
1210	1526	33299	1982	2496	54527	3099	3908	85249	4842	6105	133198	7684	9680	211384	11481	14427	315835	16812	27054	400944	23519	37846	563148	44306	71297	118236
1406	1780	36477	2303	2913	59731	3600	4559	93386	5625	7123	145911	8928	11293	231571	13339	16832	345980	19511	31563	439213	27294	44154	616897	51419	83180	122496
1602	2035	39400	2623	3329	64517	4100	5210	100868	6406	8140	157602	10167	12907	250125	15190	19236	373701	22204	36071	474404	31063	50462	666325	58518	95063	132315
1797	2289	42121	2942	3745	68972	4600	5882	107833	7187	9158	168483	11406	14520	267395	17041	21641	399504	24889	40580	507159	34818	56770	712332	65592	108946	1414469
1991	2544	44676	3261	4161	73156	5098	6513	114374	7965	10176	178704	12641	16133	283615	18887	24045	423738	27568	45089	537923	38566	63077	785542			
2185	2798	47092	3578	4577	77113	5594	7164	120561	8740	11193	188370	13871	17747	298857	20724	26450	446658	30230	49598	567201	42290	69385	796411			
2572	3307	51587	4212	5410	84473	6585	8467	130268	10289	13228	206349	16329	20974	327491	24396	31259	489290	35578	58616	621141						
2958	3816	55720	4843	6242	91241	7572	9770	142650	11830	15264	222883	18775	24201	353731	28052	36068	528494									
3344	4324	59568	5476	7074	97541	8561	11073	152490	13376	17299	238272	21229	27427	378154	31718	40877	564984									
3727	4833	63181	6103	7907	103458	9542	12376	161750	14909	19334	252725	23661	30654	401098	35352	45687	599256									
4113	5342	66599	6736	8739	109054	10531	13678	170499	16454	21369	265395	26113	33881	422790												
4497	5851	69850	7364	9571	114377	11514	14981	178821	17989	23404	279398															
4884	6360	72956	7998	10400	119463																					
5269	6868	75934																								
5657	7377	78801																								
6038	7886	81567																								
	8395	84242																								
	8904	86834																								
	9412	89352																								
	9667	91800																								
	10430	94185																								

Calculus according to ISO-4126-1:2004
 "Safety valves".

