

**Full lift safety valve with spring loading.(AIT)
 Model 495**

ENG

DESCRIPTION

Specifications

- 90° angular flow.
 - Activated by direct action helicoid spring.
 - Simplicity of construction ensuring minimum maintenance.
 - Materials carefully selected for their resistance to corrosion.
- With the exception of washers and couplings, the valves are free of non-ferric materials.
- Internal body designed to offer favourable flow profile.
 - Sealing surfaces treated and balanced, making them extremely tightness, even exceeding EN 12266-1.
 - Great discharge capacity. For liquids typically used with openings similar to proportional safety valves.
 - Equipped with draining screws for removing condensation.
 - Auto-centering plug.
 - Threaded shaft with lever positioner facilitating immediate manual action.
 - Elevator, independent of the seal, designed facilitate sudden opening when the steam expands and, with any fluid, guarantees absolute opening and closing precision.
 - All the valves are supplied sealed at the set pressure requested, simulating operational conditions, and are vigorously tested.
 - All components are numbered, registered and checked. If requested in advance, material, casting, test and efficiency certificates will be enclosed with the valve, and the instruction manual, in accordance with P.E.D. 2014/68/EU.



IMPORTANT

Depending on demand:

- 1.- Blocking screw which facilitates hydrostatic testing of the container which to be protected.
- 2.- Rapid limiter to reduce the coefficient of discharge.
- 3.- Fluorelastomer (Vitón) seals, Silicone's rubber, PTFE (Teflón)... etc., achieving leakage levels

less than:

$$0,3 \times 10^{-3} \frac{\text{Pa cm}^3}{\text{sec.}}$$

The ranges of application allow certain flexibility although we recommend limiting them to:

FLUID		RANGE OF APPLICATION FOR THE SEALS						
		SET PRESSURE IN bar						
Saturated steam		0,2	1,8	4,0	4,8	7,0	30	40,0
Liquids and gases		S	V	V	T	T		
SEALS		TEMPERATURE IN °C						
		ACCORDING TO MANUFACTURERS		RECOMMENDED BY VYC				
		MINIMUM	MAXIMUM	MINIMUM	MAXIMUM	MINIMUM	MAXIMUM	
Silicone's rubber	S	-60	+200	-50	+115			
Fluorelastomer (Vitón)	V	-40	+250	-30	+150			
PTFE (Teflón)	T	-265	+260	-80	+230 (1)			

(1) For temperatures exceeding 230°C apply metallic seal only.

- 4.- Fluorelastomer (Vitón) membrane and O-ring isolating the rotating or sliding parts from the working fluid.
- 5.- Electrical contact indicating open/closed.
- 6.- Balance bellows to:
 - Protect the spring from atmospheric influences.
 - Ensure outside of valve body is totally tightness.
 - Level out external or self-generated back pressure.
- 7.- Possibility of manufacture in other types of material, for special operating conditions (high temperatures, fluids, etc.).
- 8.- Totally free of oil and grease, to work with oxygen, avoiding possible fire risks (UV-Oxygen-VBG 62).
- 9.- Special springs for critical temperatures.

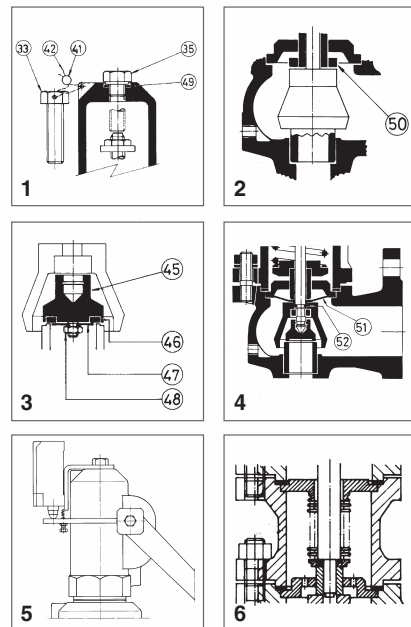

N° PIECE	PIECE	MATERIAL																			
		CAST IRON				NODULAR IRON				CAST STEEL				STAINLESS STEEL							
1	Body	Cast iron (EN-5.1301)				Nodular iron (EN-5.3106)				Cast steel (EN-1.0619+N)				Stainless steel (EN-1.4408)							
2	Closed bell	Cast iron (EN-5.1301)				Nodular iron (EN-5.3106)				Nodular iron (EN-5.3106)				Stainless steel (EN-1.4408)							
3	Open bell	Cast iron (EN-5.1301)				Nodular iron (EN-5.3106)				Cast steel (EN-1.0619+N)				Stainless steel (EN-1.4408)							
4, 5, 6	Hood	Nodular iron (EN-5.3106)				Nodular iron (EN-5.3106)				Nodular iron (EN-5.3106)				Stainless steel (EN-1.4408)							
7	Elevator	Nodular iron (EN-5.3106) (1)				Nodular iron (EN-5.3106) (1)				Nodular iron (EN-5.3106) (1)				Stainless steel (EN-1.4408) (4)							
8	Cam	Carbon steel (EN-1.0037 St-37.2) (3)				Carbon steel (EN-1.0037 St-37.2) (3)				Carbon steel (EN-1.0037 St-37.2) (3)				Stainless steel (EN-1.4301)							
9, 10	Lever	Carbon steel (EN-1.0037 St-37.2)				Carbon steel (EN-1.0037 St-37.2)				Carbon steel (EN-1.0037 St-37.2)				Carbon steel (EN-1.0037 St-37.2)							
11	Seating	Stainless steel (EN-1.4028)				Stainless steel (EN-1.4028)				Stainless steel (EN-1.4028)				Stainless steel (EN-1.4542)							
12	Plug	Stainless steel (EN-1.4028)				Stainless steel (EN-1.4028)				Stainless steel (EN-1.4028)				Stainless steel (EN-1.4542)							
13	Lead	Stainless steel (EN-1.4028)				Stainless steel (EN-1.4028)				Stainless steel (EN-1.4028)				Stainless steel (EN-1.4401)							
14	Spring press	Carbon steel (EN-1.1191)				Carbon steel (EN-1.1191)				Carbon steel (EN-1.1191)				Stainless steel (EN-1.4305)							
15	Separator	Stainless steel (EN-1.4028)				Stainless steel (EN-1.4028)				Stainless steel (EN-1.4028)				Stainless steel (EN-1.4401)							
16	Rod	Stainless steel (EN-1.4028)				Stainless steel (EN-1.4028)				Stainless steel (EN-1.4028)				Stainless steel (EN-1.4401)							
17	Lever shaft	Carbon steel (EN-1.1191)				Carbon steel (EN-1.1191)				Carbon steel (EN-1.1191)				Stainless steel (EN-1.4305)							
18	Ledgeon	Carbon steel (EN-1.1231)				Carbon steel (EN-1.1231)				Carbon steel (EN-1.1231)				Stainless steel (EN-1.4310)							
19	Ring	Stainless steel (EN-1.4028)				Stainless steel (EN-1.4028)				Stainless steel (EN-1.4028)				Stainless steel (EN-1.4401)							
20, 21	Safety ring	Stainless steel (EN-1.4310)				Stainless steel (EN-1.4310)				Stainless steel (EN-1.4310)				Stainless steel (EN-1.4310)							
22	Spring	Spring steel (EN-10270-1-SH) (2)				Spring steel (EN-10270-1-SH) (2)				Spring steel (EN-10270-1-SH) (2)				Stainless steel (EN-1.4310)							
23	Gland	Carbon steel (EN-1.1191 Ck-45)				Carbon steel (EN-1.1191)				Carbon steel (EN-1.1191)				Stainless steel (EN-1.4305)							
24	Hollow screw	Stainless steel (EN-1.4305)				Stainless steel (EN-1.4305)				Stainless steel (EN-1.4305)				Stainless steel (EN-1.4305)							
25	Hollow screw nut	Stainless steel (EN-1.4305)				Stainless steel (EN-1.4305)				Stainless steel (EN-1.4305)				Stainless steel (EN-1.4305)							
26	Buffer nut	Stainless steel (EN-1.4305)				Stainless steel (EN-1.4305)				Stainless steel (EN-1.4305)				Stainless steel (EN-1.4305)							
27	Rod check nut	Carbon steel (EN-1.1141)				Carbon steel (EN-1.1141)				Carbon steel (EN-1.1141)				Stainless steel (EN-1.4401)							
28, 29, 48	Nut	Carbon steel (EN-1.1141)				Carbon steel (EN-1.1141)				Carbon steel (EN-1.1141)				Stainless steel (EN-1.4401)							
30, 31	Washer	Carbon steel (EN-1.1141)				Carbon steel (EN-1.1141)				Carbon steel (EN-1.1141)				Stainless steel (EN-1.4401)							
32	Stud	Carbon steel (EN-1.1181)				Carbon steel (EN-1.1181)				Carbon steel (EN-1.1181)				Stainless steel (EN-1.4401)							
33, 34, 35	Screw	Carbon steel (EN-1.1191)				Carbon steel (EN-1.1191)				Carbon steel (EN-1.1191)				Stainless steel (EN-1.4401)							
36	Cap	Carbon steel (EN-1.1181)				Carbon steel (EN-1.1181)				Carbon steel (EN-1.1181)				Stainless steel (EN-1.4401)							
38	Coupling	Graphite				Graphite				Graphite				PTFE (Teflón)							
39	Coupling	PTFE (Teflón)				PTFE (Teflón)				PTFE (Teflón)				PTFE (Teflón)							
40	Seal	Graphite				Graphite				Graphite				PTFE (Teflón)							
41	Seal	Plastic				Plastic				Plastic				Plastic							
42	Sealing wire	Sealing wire				Sealing wire				Sealing wire				Sealing wire							
43	Characteristic plate	Stainless steel (EN-1.4301)				Stainless steel (EN-1.4301)				Stainless steel (EN-1.4301)				Stainless steel (EN-1.4301)							
45	Plug	Stainless steel (EN-1.4401)				Stainless steel (EN-1.4401)				Stainless steel (EN-1.4401)				Stainless steel (EN-1.4401)							
46	Sealing disk	PTFE (Teflón)				PTFE (Teflón)				PTFE (Teflón)				PTFE (Teflón)							
		Silicone's rubber				Silicone's rubber				Silicone's rubber				Silicone's rubber							
		Fluorelastomer (Vitón)				Fluorelastomer (Vitón)				Fluorelastomer (Vitón)				Fluorelastomer (Vitón)							
47	Washer	Stainless steel (EN-1.4401)				Stainless steel (EN-1.4401)				Stainless steel (EN-1.4401)				Stainless steel (EN-1.4401)							
49	Coupling	Copper				Copper				Copper				PTFE (Teflón)							
50	Limiter	Stainless steel (EN-1.4028)				Stainless steel (EN-1.4028)				Stainless steel (EN-1.4028)				Stainless steel (EN-1.4401)							
51	Membrane	Fluorelastomer (Vitón)				Fluorelastomer (Vitón)				Fluorelastomer (Vitón)				Fluorelastomer (Vitón)							
52	O-ring	Fluorelastomer (Vitón)				Fluorelastomer (Vitón)				Fluorelastomer (Vitón)				Fluorelastomer (Vitón)							
	R1 x R2	3/4" x 1 1/4" to 1" x 1 1/2"																			
	PN	16				40				40				40							
OPERATING	PRESSURE IN bar	16	13	13	13	40	35	32	28	24	40	35	32	28	24	21	20	40	34	32	29
CONDITIONS	MAX. TEMP. IN °C	120	200	250	300	120	200	250	300	350	120	200	250	300	350	400	450	120	200	250	300
	MIN. TEMP. IN °C	-10				-10				-10				-60							

(1) R.3/4" x 1 1/4" in stainless steel (EN-1.4408).

(2) Maximum temperature EP, ES and CP 250°C / AP 400°C.

(3) R.3/4" x 1 1/4" in stainless steel (EN-1.4301).

(4) R.1" x 1 1/2" in stainless steel (EN-1.4401).

R1 x R2		3/4" x 1 1/4"				1" x 1 1/2"			
CONNECTIONS		Whitworth cylindrical female thread ISO 228/1 (DIN-259)							
do		16				20			
$AO = \frac{\pi \cdot do^2}{4}$		201				314			
H		320				370			
h ¹		112				129			
L ₁		80				85			
L ₂		65				80			
R		1/4"				1/4"			
MODEL		EP	AP	ES	CP	EP	AP	ES	CP
WEIGHT IN Kgs.	CAST IRON	5,24	4,64	4,84	5,04	6,60	5,88	6,12	6,32
	NODULAR IRON	5,97	5,31	5,53	5,73	7,47	6,68	6,94	7,14
	CAST STEEL STAINLESS STEEL	5,65	5,01	5,22	5,42	7,50	6,70	6,97	7,17
CODE	CAST IRON 2002-495.	8346	83461	83462	83463	8106	81061	81062	81063
	NODULAR IRON 2002-495.	8346	83461	83462	83463	8106	81061	81062	81063
	CAST STEEL 2002-495.	8344	83441	83442	83443	8104	81041	81042	81043
	STAINLESS STEEL 2002-495.	8342	83421	83422	83423	8102	81021	81022	81023

Recommended ranges of application.
Open and closed pressures in % of set pressure.
Set pressures and regulating ranges.
Coefficient of discharge.
Discharge capacity.

See brochure Model 496.

Model 495 R. 3/4" x 1 1/4" = Model 496 DN - 20x32. do = 16.
Model 495 R. 1" x 1 1/2" = Model 496 DN - 25x40. do = 20.

