

INTERMITTENT BLOWDOWN VALVES

VPA26/2

ENG

DESCRIPTION

The VPA26/2 series of blowdown valves are specially designed for application on steam boilers, to remove sludge sediments which naturally settle on the bottom of the boiler. These intermittent valves operate manually or automatically with timed control.

Available with diaphragm actuator and/or manual operation lever.

MAIN FEATURES

High quality hardened valve seat and plug.

Manual or automatic intermittent timed control.

Lockable in open position if supplied with manual operation lever.

Practical foot operated lever.

Maintenance free stem sealing.

Tool-free quick exchangeable clamped-in seats, allowing fast and easy inline maintenance procedures.

OPTIONS AND

ACCESSORIES:

- Air filter regulator.
- Solenoid valve with timer control unit.
- Blowdown controllers.
- Mechanical limit switches.
- Inductive limit switch box.
- Water actuated version.

USE: Intermittent blowdown of steam boilers.

AVAILABLE

MODELS: VPA26/2S – carbon steel.
VPA26/2i – stainless steel.

SIZES: 3/4" to 2" – DN 20 to DN 50.

CONNECTIONS: Flanged EN 1092-1 PN 40.
Flanged ASME B16.5 Class 300.



CE MARKING – GROUP 2 (PED – European Directive)

PN 40	Category
3/4" to 1" – DN 20 to 32	SEP
1 1/2" to 2" – DN 40 to 50	1 (CE Marked)

BODY LIMITING CONDITIONS					
VPA26/2S				VPA26/2i	
FLANGED PN 40 *		FLANGED CLASS 300 **		FLANGED PN 40 *	
ALLOWABLE PRESSURE	RELATED TEMPERATURE	ALLOWABLE PRESSURE	RELATED TEMPERATURE	ALLOWABLE PRESSURE	RELATED TEMPERATURE
40 bar	-10 °C/50 °C	50 bar	-10/50 °C	40 bar	-10 °C/50 °C
33,3 bar	200 °C	43,9 bar	200 °C	33,7 bar	200 °C
30,4 bar	250 °C	36,9 bar	350 °C	31,8 bar	250 °C
27,6 bar	300 °C	34,6 bar	400 °C	29,7 bar	300 °C
23,8 bar	400 °C			27,4 bar	400 °C

* Rating according to EN 1092-1:2018; ** Rating according to EN 1759-1:2004

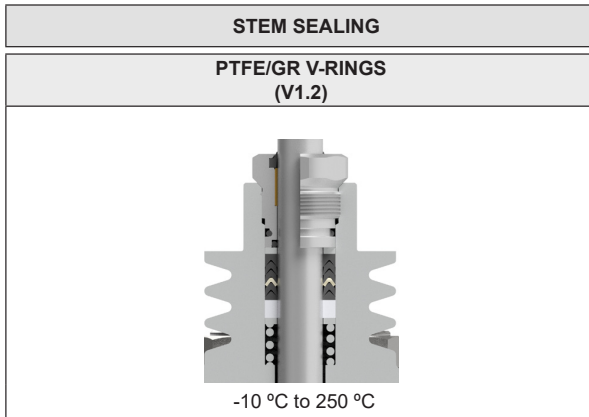

FLOW RATE COEFFICIENTS (m³/h)

	SIZES				
	3/4" – DN 20	1" – DN 25	DN 32	1 1/2" – DN 40	2" – DN 50
Kvs	6,3	6,3	6,3	16	16

For conversion $Kvs = Cv (US) \times 0,865$.

ACTUATOR DATA

DIAPHRAGM AREA	100 cm²
SPRING RANGE	2 to 3,2 bar
STROKE	12 mm
AMBIENT TEMPERATURE	-20 °C to 70 °C

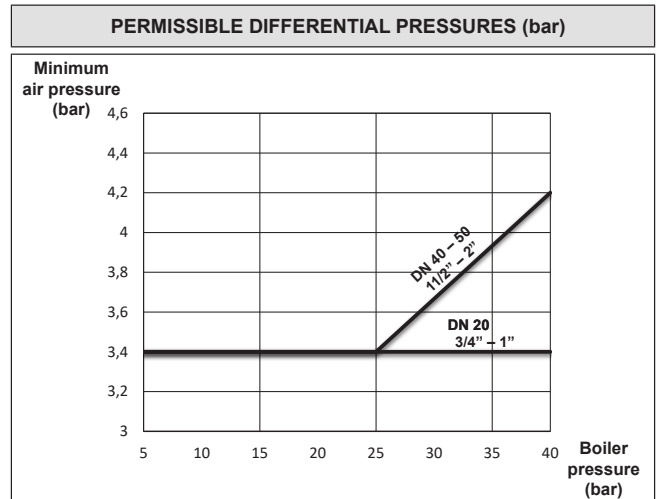

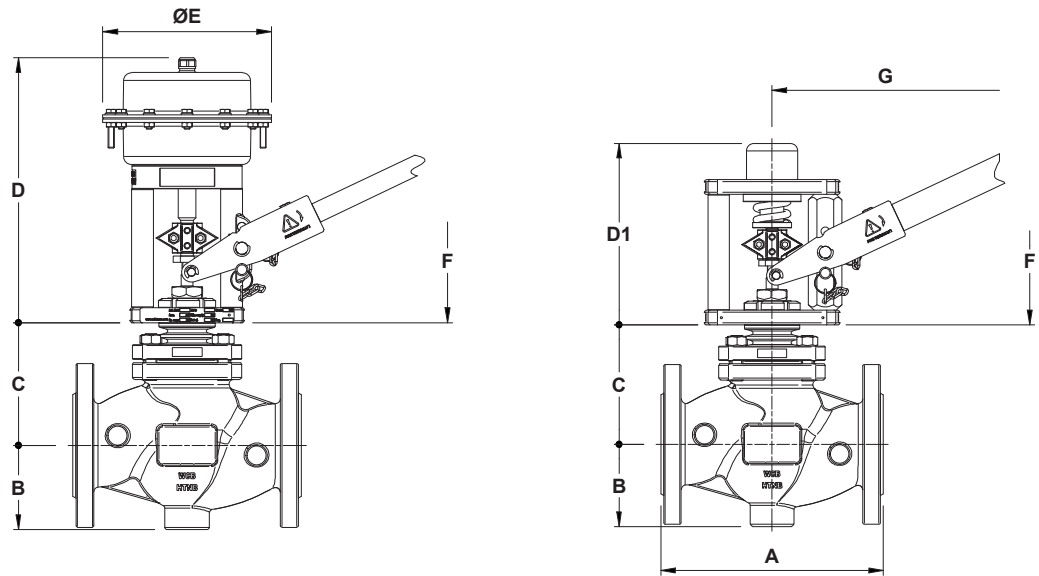





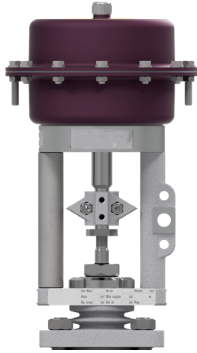
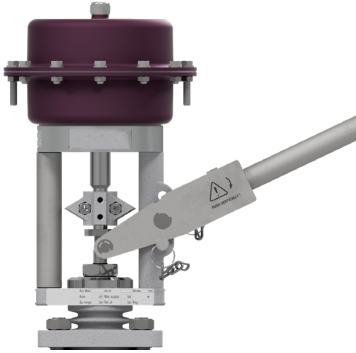
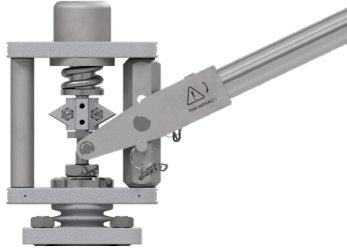

DIMENSIONS (mm)						
DIMENSION		SIZE				
		3/4" – DN 20	1" – DN 25	DN 32	1 1/2" – DN 40	2" – DN 50
A	EN	150	160	180	200	230
	ASME	194 a)	197	–	235	267
B		53	53	58	70	75
C		104,5	104,5	109,5	109,5	113
D		267				
D1		188				
E		170				
HAND LEVER	F	216			297	
	G	415			655	
FOOT LEVER	F	211				
	G	417				

a) With welded-on flanges.

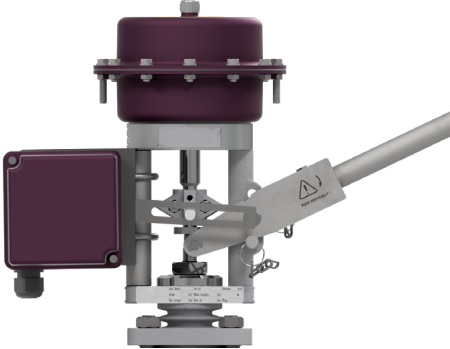
WEIGHTS (kg)						
		SIZE				
		3/4" – DN 20	1" – DN 25	DN 32	1 1/2" – DN 40	2" – DN 50
EN a)		12,5	13,4	16,1	19	22,7
EN b)		11,5	12,4	15,5	20,5	24,3
ASME a)		12,5	14,2	–	20,4	23,9
ASME b)		11,6	12,9	–	21,8	25,5

a) Valve with pneumatic actuator only; b) Valve with hand lever only.

OPTIONS AND ACCESSORIES	
<p>VALVE WITH PNEUMATIC ACTUATOR ONLY</p> 	<p>VALVE WITH PNEUMATIC ACTUATOR AND MANUAL OPERATION LEVER</p> 
<p>VALVE WITH MANUAL OPERATION LEVER ONLY</p> 	<p>SOLENOID VALVE AND AIR FILTER REGULATOR</p> 
<p>INDUCTIVE LIMIT SWITCH BOX</p> 	<p>MECHANICAL LIMIT SWITCHES</p> 

MANUAL OPERATION LEVER VERSIONS	
HAND LEVER	FOOT LEVER
	

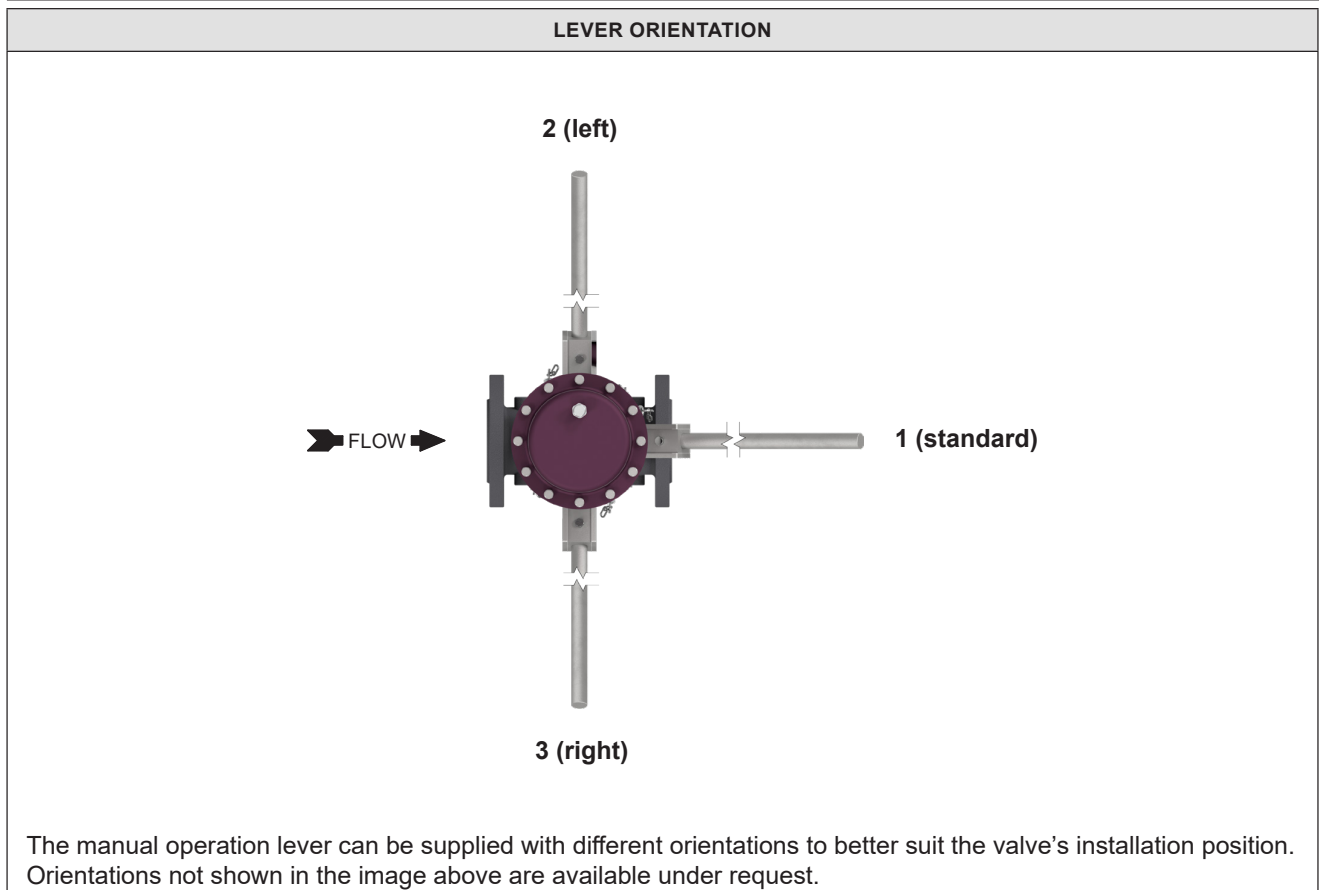

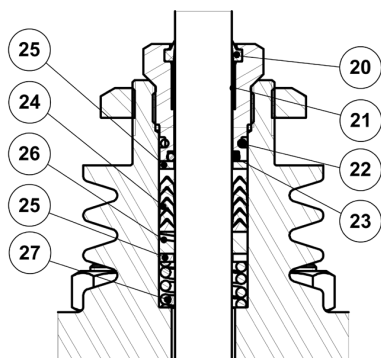
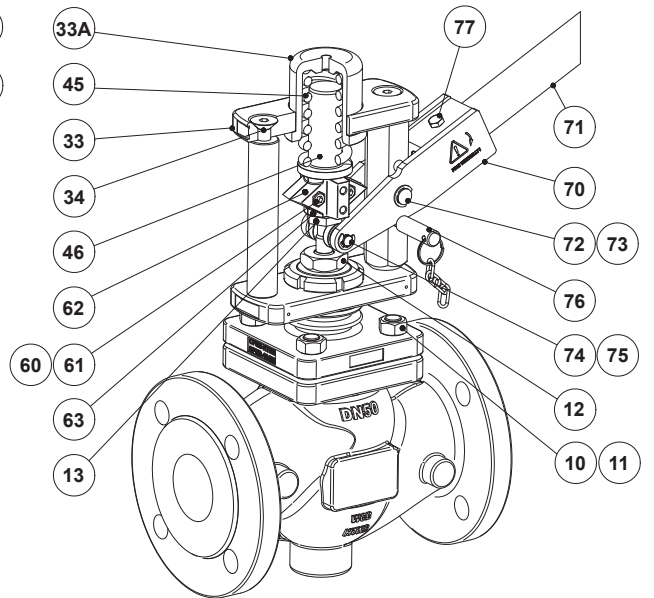
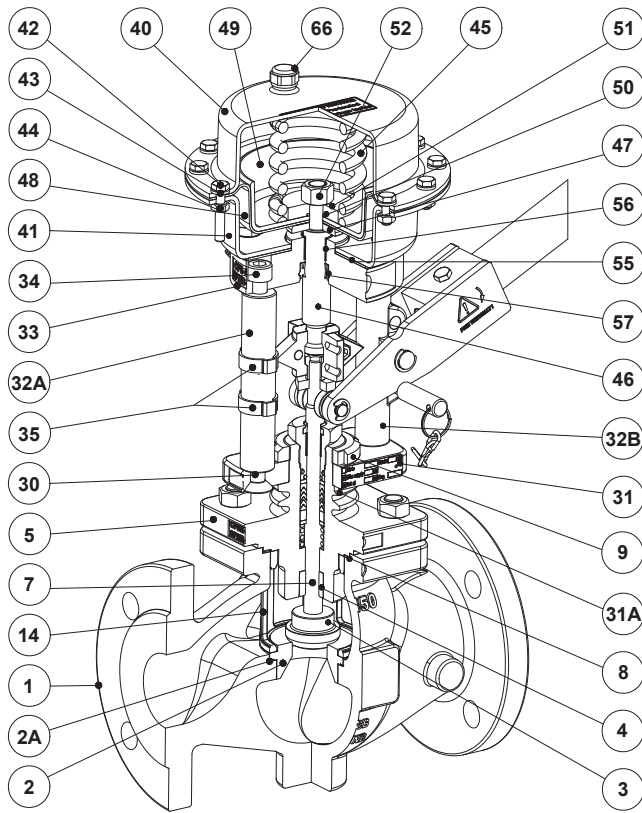

PTFE/GR V-RINGS
 (V1.2)

MATERIALS		
POS. N°	DESIGNATION	MATERIAL
1	Valve body (VPA26/2S)	A216 WCB / 1.0619
	Valve body (VPA26/2i)	A351 CF8M / 1.4408
2	* Sea	Hardened stainless steel
2A	* Seat gaske	Stainless steel / Graphite
3	* alve plug	Hardened stainless steel
4	Lower stem guide	Bronze CB1
5	Bonnet	A351 CF8M / 1.4408
7	* Ste	AISI 316L / 1.4404
8	* Gaske	Stainless steel / Graphite
9	Actuator lock nut	A351 CF8 / 1.4308
10	Nuts (VPA26/2S)	Steel 8.8
	Nuts (VPA26/2i)	Stainless steel A2-70
11	Studs (VPA26/2S)	34CrNiMo6 / 1.6582
	Studs (VPA26/2i)	Stainless steel A2-70
12	Packing nut	AISI 303 / 1.4305
13	Lock nut	AISI 304 / 1.4301
14	Seat retainer	A351 CF8M / 1.4408
20	* Scraper rin	Viton
21	* Plain bearin	Bronze / PTFE
22	* O-rin	EPDM
23	* O-rin	Viton
24	* Chevron packing se	PTFE; Graphite filled PTFE
25	Washer	AISI 304 / 1.4301
26	Stem guide	Stainless steel filled PTFE
27	Spring	AISI 302 / 1.4300
30	Bolts (steel)	Zinc plated steel
	Bolts (stainless steel)	Stainless steel A2-70
31	Lower actuator flange	A351 CF8 / 1.4308
31A	Cylindrical pin	AISI 303 / 1.4305
32A	Yoke column (steel)	C45E / 1.1191
	Yoke column (stainless steel)	AISI 303 / 1.4305
32B	Yoke lever column (steel)	C45E / 1.1191
	Yoke lever column (stainless steel)	A351 CF8 / 1.4308
33	Upper actuator flange	A351 CF8 / 1.4308
33A	Upper spring carrier	C45E / 1.1191
34	Bolts	Zinc plated steel
35	Crimp clamps	Zinc plated steel
40	Upper actuator cover	DD13 / 1.0335
41	Lower actuator cover	DD13 / 1.0335
42	Bolts (steel)	Zinc plated steel
	Bolts (stainless steel)	Stainless steel A2-70
43	Washers (steel)	Zinc plated steel
	Washers (stainless steel)	AISI 304 / 1.4301
44	Nuts (steel)	Zinc plated steel
	Nuts (stainless steel)	Stainless steel A2-70
45	Spring	Spring steel
46	Actuator stem	AISI 316 / 1.4401

MATERIALS		
POS. N°	DESIGNATION	MATERIAL
47	Lower diaphragm disc	C45E / 1.1191
48	Diaphragm	Reinforced NBR
49	Diaphragm plate	DD13 / 1.0335
50	* O-rin	NBR
51	Spring guide	AISI 304 / 1.4301
52	Nut	Zinc plated steel
53	Bolts	Zinc plated steel
54	Washers	Zinc plated steel
55	* Gaske	NBR
56	* Plain bearin	Steel / PTFE
57	* Seal rin	Polyurethane
60	Bolts (steel)	Zinc plated steel
	Bolts (stainless steel)	Stainless steel A2-70
61	Nuts (steel)	Zinc plated steel
	Nuts (stainless steel)	Stainless steel A2-70
62	Coupling / travel indicator	A351 CF8 / 1.4308
63	Adapter	AISI 304 / 1.4301
65	Fitting	Zinc plated steel; plastic
66	Vent plug	Brass; plastic
70	Lever	AISI 316 / 1.4401
71	Hand lever handle	AISI 304 / 1.4301
	Foot lever handle	S235JR / 1.0038
72	Lever axis shaft	AISI 304 / 1.4301
73	Elastic ring	AISI 304 / 1.4301
74	Roller	AISI 304 / 1.4301
75	Elastic ring	AISI 304 / 1.4301
76	Lever locking pin	AISI 304 / 1.4301
77	Lever fixing bolt	Stainless steel A2-70



ORDERING CODES VPA26/2											
Valve model	VP26	2	S	AX	0	SX	1	FE	N	20	
Intermittent bottom blowdown valve, two way, straight body	VP26										
Valve series											
Series 2		2									
Body material											
A216 WCB / 1.0619 carbon steel			S								
A351 CF8M / 1.4408 stainless steel			I								
Versions											
Valve with actuator only				AX							
Valve with actuator and hand lever				AH							
Valve with actuator and foot lever				AF							
Valve with hand lever only				XH							
Valve with foot lever only				XF							
Lever orientation											
Without lever					0						
Standard position					1						
Lever rotated 90° to the left (relative to the flow direction)					2						
Lever rotated 90° to the right (relative to the flow direction)					3						
Actuator											
Steel construction						SX					
Stainless steel construction						IX					
Steel construction – water actuated						SW					
Stainless steel construction – water actuated						IW					
Without actuator						XX					
Stem sealing											
PTFE/GR V-rings (V1.2)							1				
Flow rate coefficient											
Kvs 6,3 (available only for 3/4" to 1" and DN 20 to DN 32)								FE			
Kvs 16 (available only for 1 1/2" to 2" and DN 40 to DN 50)								FG			
Pipe connection											
Flanged EN 1092-1 PN 40									N		
Flanged ASME B16.5 Class 300 a)									V		
Size											
3/4" or DN 20											20
1" or DN 25											25
DN 32											32
1 1/2" or DN 40											40
2" or DN 50											50
Special valves / Extras											
Full description or additional codes have to be added in case of a non-standard combination											E

a) Not available with A351 CF8M / 1.4408 stainless steel body (VPA26/2i).

